



METAL SKIN PLATINUM 60 TAMPER

Technical Specifications

- **RF protocol** ISO/IEC 18000-6C (EPC Gen2)
- **Frequency** 902-928 MHz (US);
865-868 MHz (EU)
- **IC type(chip)**¹ NXP UCODE 9
- **Chip memory**² 96 bits EPC; 96 bits TID
- **Write cycles** 100,000 times
- **Data retention** 20 years
- **Read range** fixed³
Up to 14.76 ft (4.50 m) on metal
- **Polarization** Linear

Key Features

- + **Tamper-Proof:** for asset protection
- + **Flexible label:** for curved surfaces
- + **Printable:** human and computer-readable
- + **IP68 rating:** waterproof

Applications

- High-value assets tracking
- Hospital equipment
- MRO parts and components

Environmental Specifications

Temperatures



- **Operational** -40°C to +85°C
-40°F to +185°F
- **Survival** -40°C to +85°C
-40°F to +185°F

- **IP rating** IP68
- **Storage Humidity** 50±15%RH
- **Printer compatibility** SATO CL4NX,
Zebra ZT411R, Postek TX3r,
TSC Printronix T6000e and T4000, etc.
- **Vibration** MIL-STD-810G
- **Warranty** 1 year

¹ The chip data retention is up to 20 years, based on chip operating under general environment conditions.

² EPC can be re-programmed or permanently locked, can not be password protected. TID is locked and unique at the point of manufacturing.

³ Fixed reader. Actual read range may vary based upon use case and antenna power.



Physical Specifications

- **Material** White thermal transfer face stock
- **Dimensions (in)**¹ 2.36 x 0.98 x 0.05
- **Dimensions (mm)**² 60 x 25 x 1.25
- **Packaging** 500pcs/roll
- **Weight (roll)** 1.76 lbs (0.80 kg)

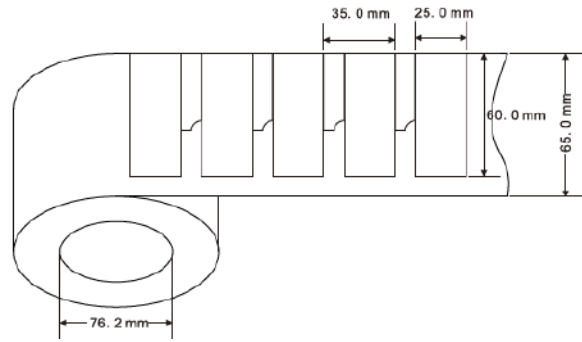

Mounting Systems

- 3M industrial adhesive

Installation Instructions

1. Clean the surface using Isopropyl alcohol, alcohol pad or equivalent solvent to ensure surface is free from dirt, dust, oil and misc, debris that may affect adhesion.
2. Handle the label by edges, peel release liner from back ensuring not to touch the adhesive.
3. Place the label in desired tagging location and firmly apply even pressure to the label for 5 seconds.
4. Do not disturb the newly mounted label for at least 15 minutes to ensure proper adhesive seating.

¹ Tolerance: Length/Width= +/- 0.02; Thickness= +/- 0.008

² Tolerance: Length/Width= +/- 0.50; Thickness= +/- 0.200

Industry Compliance



Order Information

METAL SKIN Platinum 60 Tamper US:
X6025-UST11-U9

METAL SKIN Platinum 60 Tamper EU:
X6025-EUT11-U9

Customization Options

Encoding

Printing

The information provided by Xerafy Singapore Pte. Ltd. is for general information purposes only. All information on the datasheet is provided in good faith. However we make no representation or warranty of any kind, express or implied, regarding the accuracy, adequacy, validity, reliability, availability, or completeness of any information on the datasheet.

Under no circumstance shall we have any liability to you for any loss or damage of any kind incurred as a result of the use of the product or reliance on any information provided on the datasheet. Your use of the product and your reliance on any information on the datasheet is solely at your own risk.

