

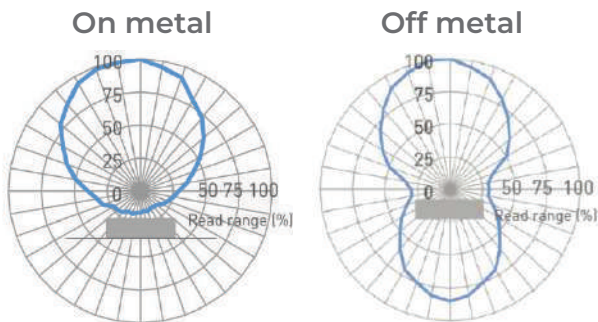

RTI OUTDOOR

Technical Specifications

- **RF protocol** EPC global Class 1 Gen 2
- **Frequency** 902-928 MHz (US); 865-868 MHz (EU)
- **IC type (chip)**¹ NXP U9xe
- **Chip memory**² 128 bits EPC; 96 bits TID
- **Read range on metal**³ Up to 55.77 ft (17 m)
- **Read range off metal**³ Up to 26.25 ft (8 m)
- **Read range on gas cylinder**³ Up to 32.81 ft (10 m)
- **Polarization** Linear
- **Radiation pattern**



Key Features

- + **Durability:** Withstands pressure washdowns and UV-proof
- + **Long read range:** up to 17m for distance reading
- + **Flexible mounting:** adhesive, glue/epoxy, rivets, or zip ties
- + **Customization:** unique ID with durable printing or laser marking

Applications

- RTI management
- LPG and gas cylinder
- Production logistics
- Yard management
- Long-distance shipping

Environmental Specifications

Temperatures



- Operational -40°C to +85°C
- Survival -40°C to +85°C (48 hours)

- **IP rating** IP68
- **Compression strength** 26 psi (180 kPa)
- **Shock** 3ft (1 m) to concrete/granite
- **Vibration** MIL-STD-810G
- **Warranty** 1 year

¹ The chip data retention is up to 50 years, based on chip operating under general environment conditions.

² EPC and User Memory can be re-programmed, password protected, or permanently locked. TID is locked and unique at the point of manufacturing.

³ Fix reader



Physical Specifications

- **Material** Anti-UV industry grade polymer
- **Dimensions (in)**¹ 2.88 x 0.90 x 0.34
- **Dimensions (mm)**¹ 73.30 x 22.80 x 8.65
- **Weight** 0.39 oz (11 g)

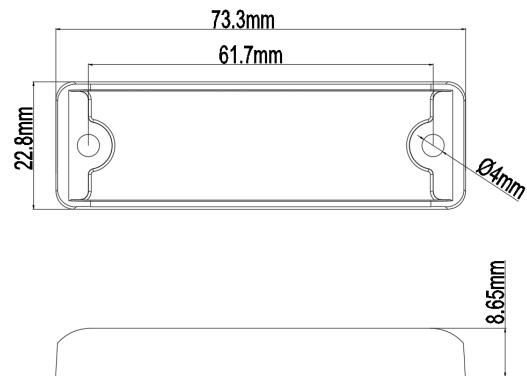

Mounting Systems

- Rivets
- Cable tie (optional)
- Epoxy (optional)
- Industrial adhesive (optional)

Installation Instructions

Use M3 rivets for RTI attachment:

1. Drill two holes (\varnothing 3.50) in the metal surface, pitch: 61.70 mm.
2. Utilize M3 rivets in conjunction with a rivet gun to securely fasten the tag onto the metal surface.

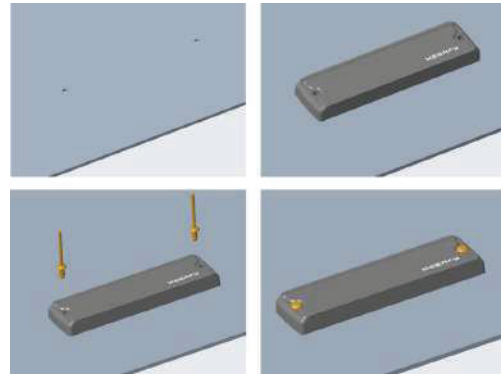

Use glue/epoxy for LPG and gas cylinders attachment:

1. Select the suitable attachment location on the gas cylinder (usually inside the protection ring).
2. Clean the surface for rugged attachment.
3. Apply glue/epoxy resin evenly on the back of the RTI tag.
4. Place the tag vertically and tightly against the gas cylinder shroud mounting location.
5. Use tape to hold the tag ends in place until the glue/epoxy cures..
6. Remove the tape after 24 hours (the time depends on the glue/epoxy used)

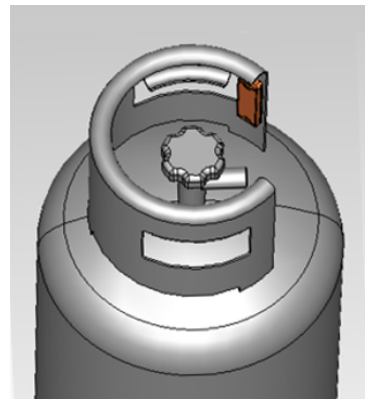

¹Tolerance: +/- 0.02; +/- 0.50

Industry Compliance



Order Information

RTI OUTDOOR US: X0352-US100-U9xe

RTI OUTDOOR EU: X0352-EU100-U9xe

Customization Options

Encoding

Laser Marking

ATEX Certified Version

Printing

Industrial Adhesives

The information provided by Xerafy Singapore Pte. Ltd. is for general information purposes only. All information on the datasheet is provided in good faith. However we make no representation or warranty of any kind, express or implied, regarding the accuracy, adequacy, validity, reliability, availability, or completeness of any information on the datasheet.

Under no circumstance shall we have any liability to you for any loss or damage of any kind incurred as a result of the use of the product or reliance on any information provided on the datasheet. Your use of the product and your reliance on any information on the datasheet is solely at your own risk.