

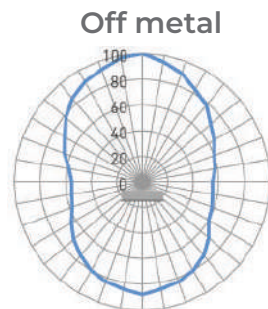

DATA TRAK II

Technical Specifications

- **RF protocol** EPC global Class 1 Gen 2
- **Frequency** 860-960 MHz (Global)
- **IC type (chip)**¹ Impinj M750
- **Chip memory** 96 bits EPC; 96 bits TID; 32 bits user memory
- **Read range on metal**² Up to 14.76 ft (4.50 m)
- **Read range off metal**² Up to 6.56 ft (2 m)
- **Polarization** Linear
- **Radiation pattern**

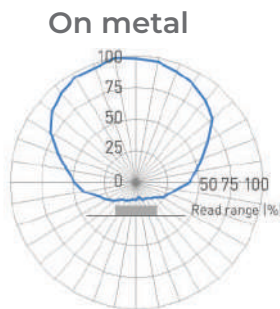

Key Features

- + **Multi-surface:** for on/off metal asset
- + **Global freq:** worldwide compatibility
- + **Various mounting systems**
- + **Cost-effective:** for high volume

Applications

- Data centers
- IT asset management
- Manufacturing WIP
- Automated inventory

Environmental Specifications

Temperatures



- Operational -40°C to +85°C
- Survival -40°C to +85°C

- **IP rating** IP54
- **Compression strength** 14.5 psi (100 kPa)
- **Shock** 3ft (1 m) to concrete/granite
- **Vibration** MIL-STD-810G
- **Warranty** 1 year

¹ The chip data retention is up to 50 years, based on chip operating under general environment conditions.

² Fixed reader

Physical Specifications

- **Material** Industry grade polymer
- **Dimensions (in)**¹ 1.50 x 0.51 x 0.16
- **Dimensions (mm)**¹ 38 x 13 x 4
- **Tethering hole diameter**² 0.10 in (2.60 mm)
- **Weight** 0.08 oz (2.40 g)

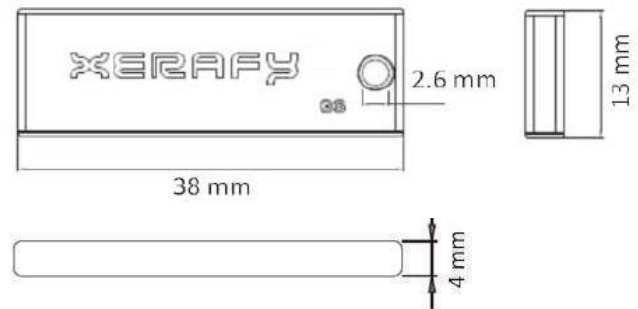

Mounting Systems

- Cable ties
- Industrial adhesive

Installation Instructions

1. Clean the surface using Isopropyl alcohol, alcohol pad or equivalent solvent.
2. Handle the tag by edges, peel release liner from back ensuring not to touch the adhesive.
3. Place the tag in desired tagging location and firmly apply even pressure to the tag for 5 seconds.
4. Do not disturb the newly mounted tag for at least 15 minutes to ensure proper adhesive seating.

* Other installation options: cable tie (tethering hole: 2.60mm, based on your application environment)

¹ Tolerance: +/- 0.02; +/- 0.50

² Tolerance: +/- 0.008; +/- 0.200

Industry Compliance



Order Information

Data TRAK II: X0330-GL011-M750

Customization Options

Encoding

ATEX Certified Version

Printing

The information provided by Xerify Singapore Pte. Ltd. is for general information purposes only. All information on the datasheet is provided in good faith. However we make no representation or warranty of any kind, express or implied, regarding the accuracy, adequacy, validity, reliability, availability, or completeness of any information on the datasheet.

Under no circumstance shall we have any liability to you for any loss or damage of any kind incurred as a result of the use of the product or reliance on any information provided on the datasheet. Your use of the product and your reliance on any information on the datasheet is solely at your own risk.